

BREW EXPRESS®

OPERATION GUIDE

model no. BE-104 & BE-110

For more information see our instructional video online at www.BrewExpress.com.

IMPORTANT NOTE:
Do not return this product to place of purchase without authorization.
For return authorization OR service call 866.268.5953

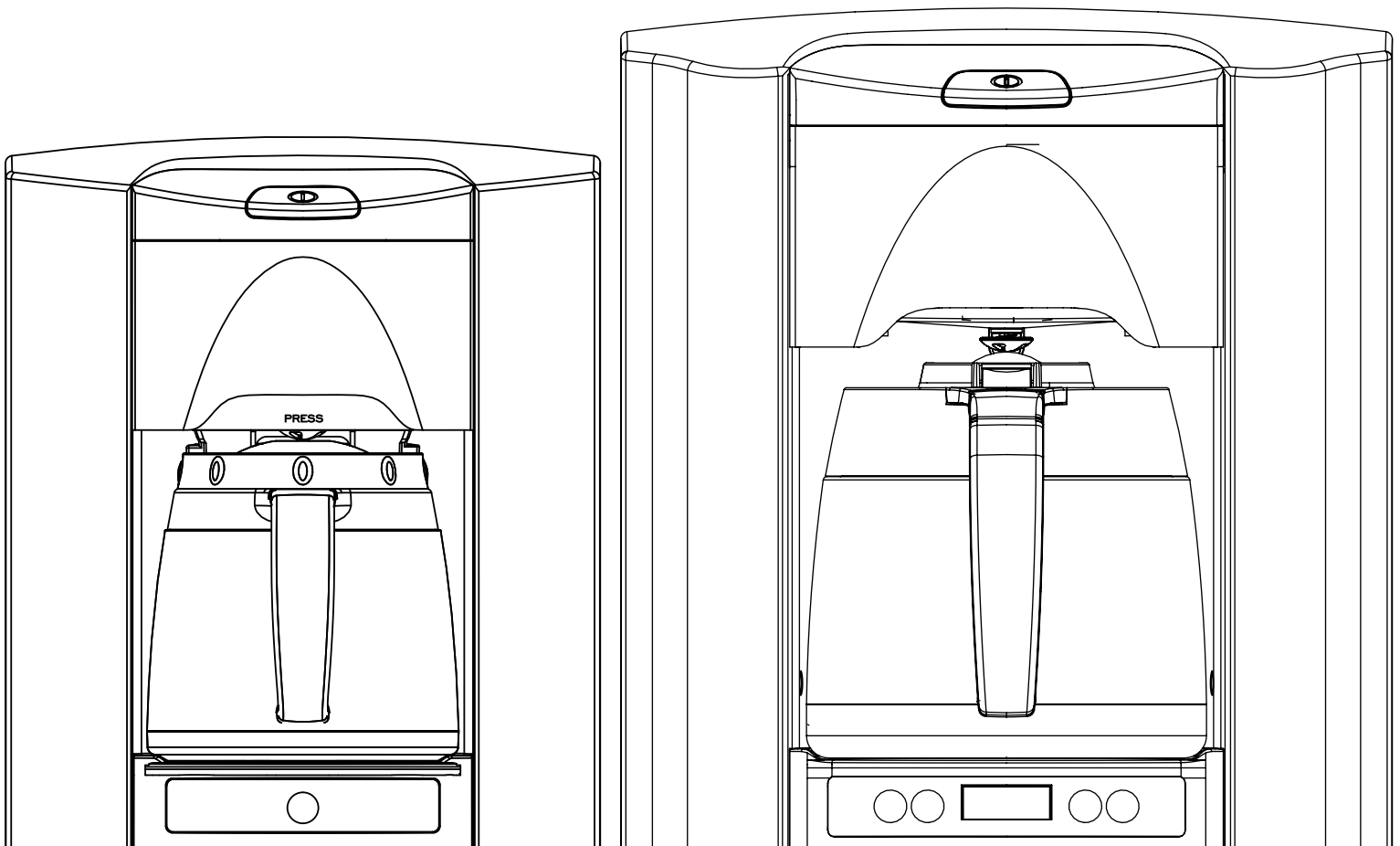

by LANCE LARKIN®

CONTENTS

1. Safety	1-2
2. Features	3
3. Controller Functions	4
4. Start Up	5
5. Operation	6 - 7
6. Maintenance	8
7. Troubleshooting	9 - 11
8. Parts & Service	12
10. Warranty Information	13

IMPORTANT SAFEGUARDS

When using electrical appliances, basic safety precautions should always be followed, including the following:

1. Read all Instructions.
2. Do not touch hot surfaces. Use handles or knobs.
3. The voltage and frequency of the supply connections should conform to those of the rating label.
4. Close supervision is necessary when any appliance is used by or near children.
5. Allow to cool before putting on or taking off parts, and before cleaning the appliance.
6. Do not operate any appliance after the appliance malfunctions, or has been damaged in any manner. Call and discuss problem with customer service.
7. The use of accessory attachments not recommended by the appliance manufacturer may result in fire, electric shock or injury to persons.
8. Do not use outdoors.
9. Do not place on or near a hot gas or electric burner, or in a heated oven.
10. The appliance should be installed in a place not easily reached by children.
11. Do not use appliance for other than intended use.
12. To reduce the risk of shock, discontinue use of the appliance if water leakage occurs.
13. To reduce the risk of fire, do not place any heating or cooking appliance beneath the appliance.
14. To reduce the risk of fire, do not mount unit over or near any portion of a heating or cooking appliance.
15. To reduce the risk of electric shock, do not mount over a sink.
16. To reduce the risk of fire, do not store anything directly on top of the appliance surface when the appliance is in operation.

SAVE THESE INSTRUCTIONS

SAFETY

IMPORTANT:

Please read and follow instructions carefully before starting your BREW EXPRESS in-the-wall COFFEE SYSTEM.



The BREW EXPRESS dispenses extremely hot water. Hot liquids may cause severe burns if it contacts skin. Use extreme caution when handling hot liquids dispensed by the BREW EXPRESS. KEEP HANDS AWAY FROM SPRAY HEAD, BREW BASKET, CARAFE OR MUG DURING BREW CYCLE.

- DO NOT use carafe or mug that is cracked or damaged.
- DO NOT remove the brew basket while brewer is in operation.
- DO NOT place carafe in microwave or place on stove top.

FEATURES

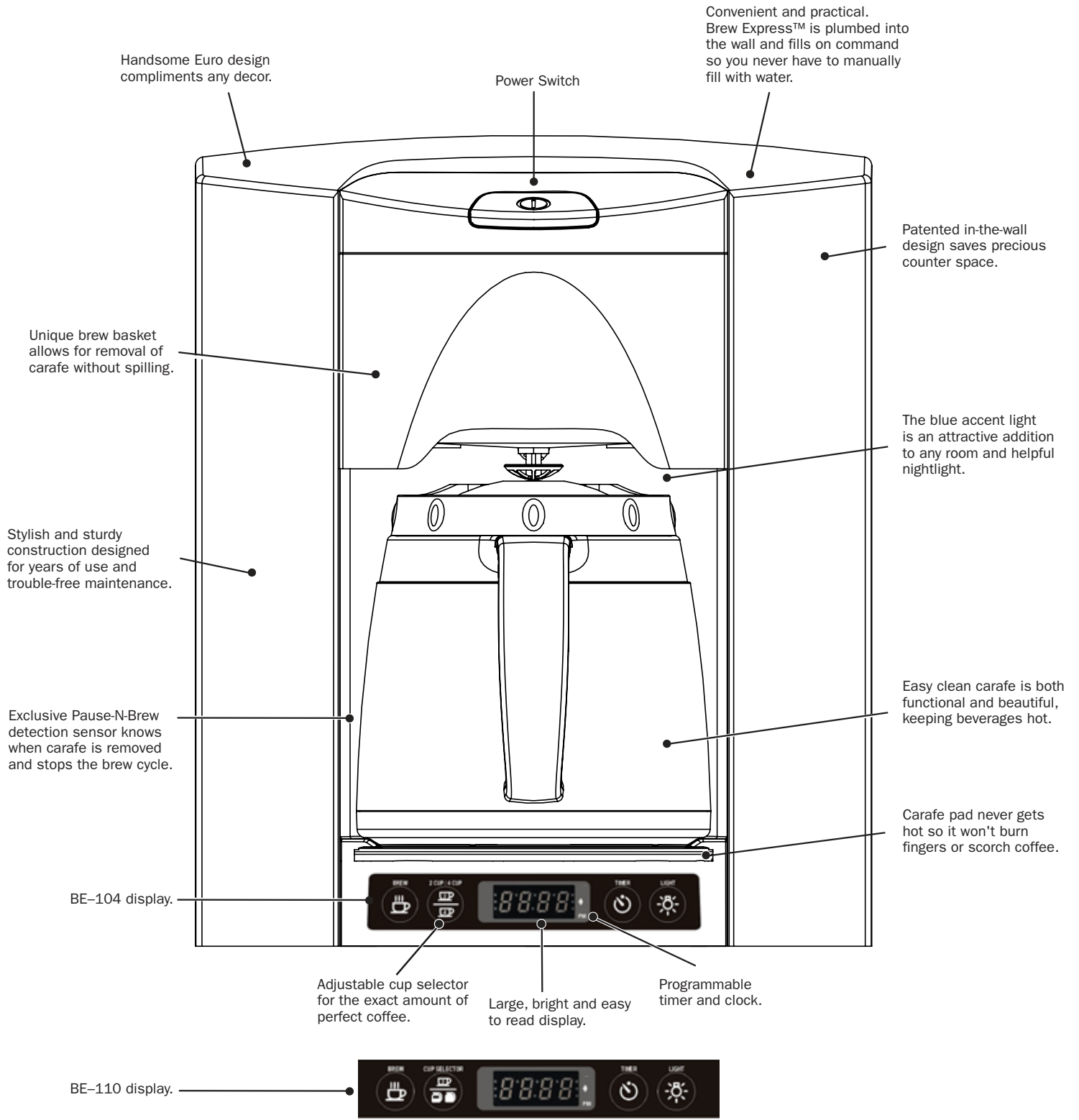

CONTROL FUNCTIONS

Display Panel

Brew Button

Starts brew cycle. Brewing stops automatically or by pressing the brew button again.

Status Light

Green (steady) – wait mode

Red (steady) – brew mode

Red (slow blinking) – carafe or mug not detected

Red (fast blinking) – no water

Adjustable Cup Selector

Selects the amount of water to be used during brew cycle:

BE-104 - 2 cup/1 mug (8 oz), 4 cup (18 oz)*

BE-110 - 2 cup (8 oz), 1/2 carafe (23 oz), full carafe (45 oz)*

* volumes may vary slightly

Clock

Continuously displays current time and is used for setting automatic brew time.

PM Indicator

Indicates PM for clock.

Beeper On/Off Indicator Light

Indicates if brew complete beeper is on or off.

Auto Timer Switch & Indicator Light

Turns on automatic brew cycle at set time.

Accent Lighting Button

Turns on and off accent lighting located behind brew basket.

PROGRAM DISPLAY PANEL

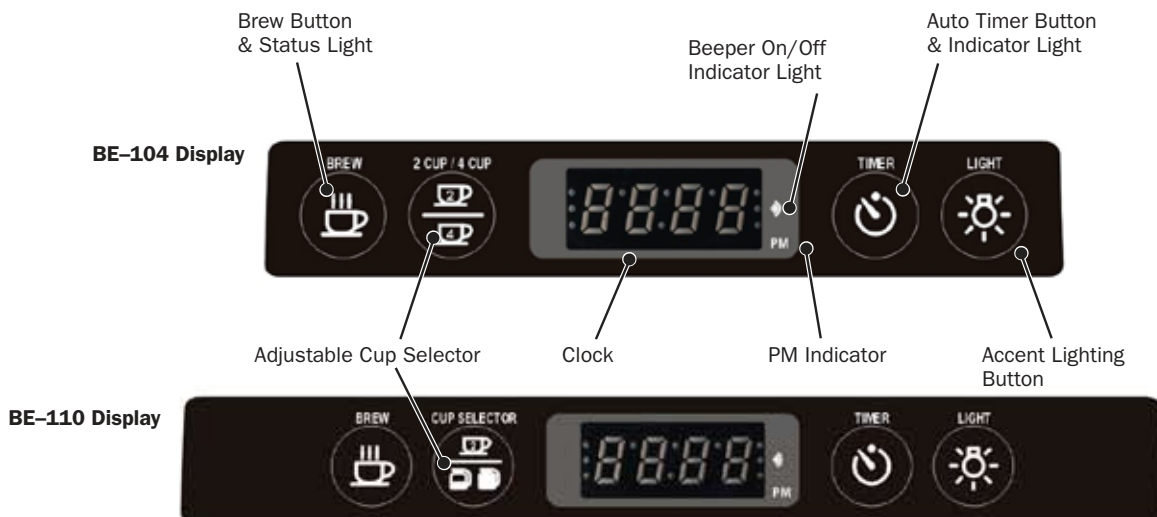

IMPORTANT:

Please read and follow instructions carefully before starting your BREW EXPRESS in-the-wall COFFEE SYSTEM.



Did you purge water lines during installation to remove any foreign particles (debris) in lines? Debris in water lines can clog brewer system causing failure, and VOID ALL WARRANTIES.



The BREW EXPRESS dispenses extremely hot water. Hot liquids may cause severe burns if it contacts skin. Use extreme caution when handling hot liquids dispensed by the BREW EXPRESS. KEEP HANDS AWAY FROM SPRAY HEAD, BREW BASKET, CARAFE OR MUG DURING BREW CYCLE.

- 1.** Make sure water supply is turned on prior to starting BREW EXPRESS.
The BREW EXPRESS will not operate if there is no water.
- 2.** Make sure power is supplied to the BREW EXPRESS.
- 3.** Turn on power switch, depress button on top of unit. Brew button and LED display will illuminate.
- 4.** Flush brewing system by running two cycles of water through the brewer. Place brew basket under spray head without coffee or filter, place empty carafe under brew basket and press the brew cycle button. After brewing cycle is complete, empty carafe and repeat.
- 5.** Wash carafe and brew basket with warm soapy water.

IMPORTANT REMINDERS

- Always empty carafe prior to starting the unit, otherwise overflowing can occur.**
- Use appropriate brew basket with carafe and mug.**

OPERATION

1. Power Switch

Switch located on top of brewer. Depress button to turn on power

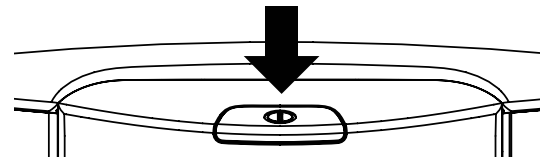

2. Set Clock

The clock is preset to 12:00 noon when power is first applied.

To set the time, follow these steps:

- Press and hold the "Light" button for 5 seconds.
- Press "Brew" button to toggle between 12 and 24 hour clock. AM/PM light is off for 24 hour clock.
- Press the "Cup Selector" button to set hours. Note AM/PM indicator light. Holding down button advances hours.
- Press the "Timer" button to set the minutes. Holding down button advances minutes.
- Press "Light" button to finish time setting.

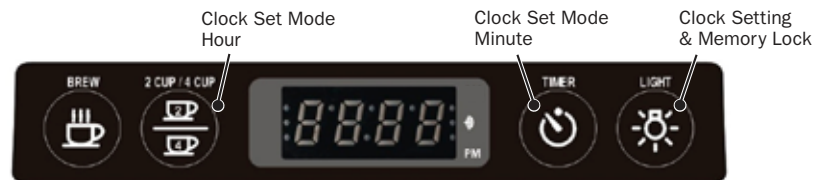

3. Set Up Brew Basket

For brewing into the carafe use the carafe brew basket (with stopper). For brewing into a mug use the single cup brew basket (cone style). Select the appropriate filter and place into brew basket. Add desired amount of coffee for taste preference (typically 1 tbsp per cup). Slide the brew basket into the brewer.

CAUTION – Ensure brew basket is completely inserted, otherwise problems may occur such as excessive steam or overfilling.

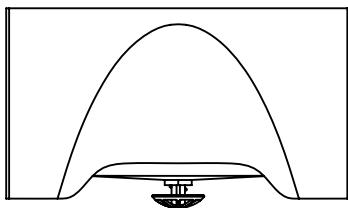

Carafe
Brew Basket

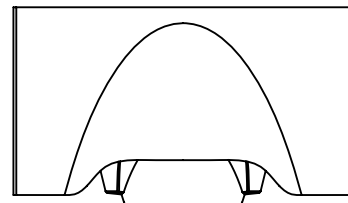

Single Cup
Brew Basket
(cone style)

4. Coffee Filter Selection

10-12 cup flat bottom filter for carafe, #4 cone filter for single cup brew basket. Filters vary in height. It is important to select a filter that extends to the top of the brew basket, otherwise coffee grounds may overflow the filter.

5. Position Carafe or Mug

Position an **EMPTY** carafe or mug in the BREW EXPRESS under the brew basket. The detection sensor will not allow the brewer to operate unless the carafe or mug is positioned under the brew basket. The brew light will blink if nothing is detected. When using a cup or mug, place it back far enough to activate sensor.

WARNING: ALWAYS EMPTY CARAFE OR MUG PRIOR TO STARTING THE UNIT OR OVERFILLING WILL OCCUR.

6. Cup Selection

Select the amount of water by pressing the "Cup Selector" button. The icons on the button will illuminate to indicate selection. The volume of water for each setting is approximately 8 oz (2 cup), 23 oz (1/2 carafe) and 50 oz (full carafe). The volume of water for each setting can be increased if desired. This is done by increasing the brew time (see below).

To increase volume:

- Select volume to change using the "Cup Selector" button.
- Press and hold the "Cup Selector" button for 5 seconds.
- The display now shows the current time duration (default: 2 cup = 70 sec, 1/2 carafe = 180 sec, full carafe = 350 sec).
- Press the "Cup Selector" button to increase time and "Timer" button to decrease time (8 sec = ~ 1 oz).
- Press "Light" button to finish changing the brew duration.



7. Manual Brew Cycle

To manually start a brew cycle press the “Brew” button. The brew light will turn red once the cycle has started. If brewer is cold, the heater will preheat the water before starting the brew cycle. After the selected amount of water is dispensed, the brew light will blink for 40 seconds. At that time the BREW EXPRESS will beep 4 times.

8. Automatic Brew Cycle

To automatically start a brew cycle press the “Timer” button. The button will illuminate and the start time will blink 5 times on the clock display.



To program the start time:

Press and hold the “Timer” button for 5 seconds.

Press the cup selector button to set hours. Note AM/PM indicator light. Holding down button advances hours.

Press the “Timer” button to set the minutes. Holding down button advances minutes.

Press “Light” button to finish time setting.

9. Pause-N-Brew Feature

The BREW EXPRESS carafe can be removed during brew cycle to pour a cup of coffee. The detection sensor will stop the flow of water and the valve on the brew basket will prevent existing water from spilling. Once carafe is returned, operation will continue. If carafe is missing for over 5 minutes, BREW EXPRESS will shut off automatically.

10. Accent Lights

To turn on and off the accent lights press the “Light” button. The accent lights are located behind the brew basket.

11. Sound Setting (Beeper On/Off)

At the end of a brew cycle a beeper is sounded 4 times.

To turn off the beeper:

Press and hold the “Brew” button for 5 seconds.

A single beep will indicate the sound is off. Also, the beeper indicator light will be off.

Two beeps will indicate the sound is on. Also, the beeper indicator light will be on.

12. Optional Carafe Lock

An optional carafe lock is available. This device prevents the carafe from moving in mobile applications (marine, recreational vehicles), or it prevents accidental removal by children.

The carafe lock consists of a lock lever and spring. It installs easily by depressing the sides of the lock lever until the pins slide into the mounting holes on the brew basket. The spring slides over a pin on the back of the brew basket and into a hole on the lock lever.

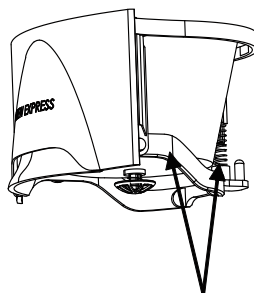

lock lever and spring

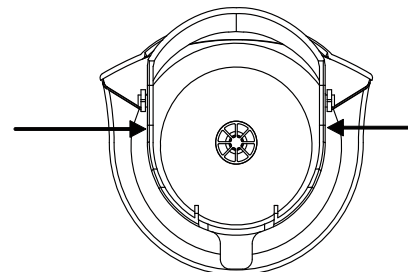

depress sides of lock lever to install

MAINTENANCE

Cleaning

Carafe

Clean the carafe and lid after each use with warm water and a mild dish soap.

Brew Basket

The brew basket should also be cleaned after each use with mild dish soap and warm water. The brew basket is dishwasher safe (top rack only).

Spray Head

It is recommended the spray head be cleaned occasionally with mild soap and warm water depending on the amount of use. When the unit is cool, remove the spray head by gently rotating it by hand counter clockwise. After cleaning, reinstall the sprayhead and hand tighten only. Be careful not to damage spray head.

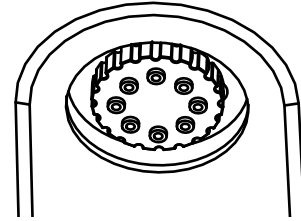

Brewer Exterior

Clean the exterior of the brewer with a soft damp cloth and mild soap. Avoid getting excessive water around buttons and detection sensors. **DO NOT** use abrasive cleansers, they will damage the surface of the brewer. Also, do not use ammonia (Windex), denatured alcohol or chlorinated based cleaners. They will damage the plastic.

Removing Brewer from Wall

If brewer must be removed from wall for repair or cleaning. Follow this procedure.

1. Place cardboard or towel on counter in front of brewer to protect counter surface.
2. Remove screws (2) from behind carafe & brew basket.
3. Firmly grab side edges of brewer with both hands and gently pull straight forward until brewer moves approximately 1”.
4. Gently rotate the left side of brewer away from the wall until there is sufficient room to reach inside the rough-in-box.
5. Carefully reach behind brewer and disconnect the water supply line by pressing on the gray button on the connector from the water line to the brewer.

For more assistance see our instructional video online at www.BrewExpress.com.

No power or display is not illuminated

- **Press power button** (on top of brewer).
- Confirm the power to the rough-in box is turned on (check circuit breaker).
- Confirm brewer is fully pressed into the rough-in box.
- Check the outlet inside rough-in box. Remove the brewer and check outlet by plugging in another appliance (lamp, etc). If there is no power, then turn off power to circuit and check wiring.

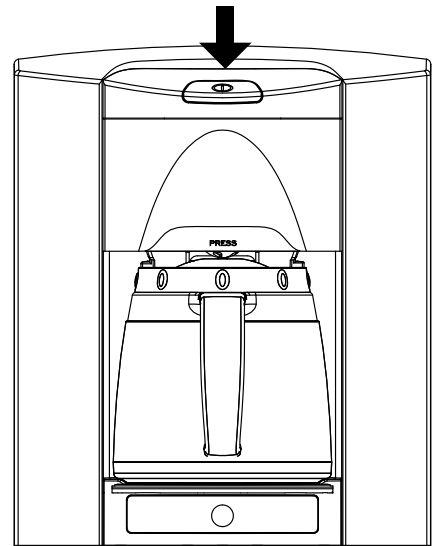

Water does not flow from spray head

- The BREW EXPRESS preheats the water before starting the brew cycle. You may be waiting for the preheat cycle to end.
- Confirm the carafe or mug is centered under the brew basket. BREW EXPRESS will not start if the detection sensor does not see a carafe or mug. Brew light will blink slowly. If using a mug, one may need to move it further inside brewer.
- The BREW EXPRESS will not operate if there is no water. LED display will flash EEEE if there is no water.
- Confirm the water is connected to brewer and is turned on.
- Confirm the water line is properly connected inside the rough-in box. Remove the two mounting screws from behind the brew basket and carafe and pull out brewer. The water line quick connectors must be pressed together firmly. Also, check for a pinched or kinked water line.
- Check quick connections to insure they are snapped together and that water is on.
- Check the water filter (if present) at the supply. If filter is clogged replace filter.
- If problem persists, then brewer maybe clogged by debris. Call customer service.
- If outside air temp is below freezing then check to see if water line is frozen.

Water overflow from carafe

- Carafe was not emptied before brew cycle started (empty carafe).
- Flow rate too high, confirm by running 2-3 pots of water, if flow rate is still too high call for customer service.

Water volume in carafe is too low

- Increase brewing time. See procedure on page 6.
- Check sprayhead for blockage.

TROUBLESHOOTING

Water overflow from brew basket

- Paper filter is not high enough and grounds are flowing over and plugging brew basket (Bunn brand works well).
- Grind of coffee may be too fine, try a coarser grind.

Excessive Steam

- Inlet water line connected to hot water supply (connect to cold water).
- Spray head is plugged (remove spray head and clean or replace).
- Water flow is too low, confirm by running a full carafe and checking volume. Possible water hardness issues – call for service.

Taste Not Acceptable

- Quality or quantity of coffee placed in brew basket is not sufficient (purchase better quality coffee).
- Adjust coarseness of coffee grind.
- Spray head is plugged and water is boring hole in grounds (clean or replace spray head).
- Check temperature inside of a full carafe of water. It is possible heating system is not working properly.

Coffee temperature cold or luke warm

- Carafe not keeping coffee hot enough. If using 2 cup or 1/2 carafe setting, consider pre-heat it with hot water before brewing.
- Water flow rate too high or heater failed, call customer service.

Cup or mug not detected (flashing brew light)

- Mug not close enough to detect sensor (move further into brewer).

Water dripping from spray head

- Normally some water will drip from the spray head shortly after brewing.
- Debris may be inside valve. Disconnect water and reconnect, then run 1-2 full cycles of water in carafe. If problem persists, contact customer service.

Programmed start time not working properly

- Review instructions on page 6 (Automatic Brew Cycle).

**Spare parts are available from Lance Larkin (866) 268-5953 or email info@lancelarkin.com
Contact Lance Larkin for all service and warranty issues.**

- Spray head
- Brew Baskets (flat bottom and cone)
- Carafe and lid
- Mounting screws
- Auxiliary water pump (for installation in areas without water supply)

WARRANTY

I YEAR LIMITED WARRANTY

This limited warranty is the only one that applies to this product, and sets forth all the responsibilities of Lance Larkin regarding this product. There is no other warranty, other than that described herein.

BREW EXPRESS is warranted, to the original purchaser only, to be free of defects for parts and labor for a period of 1 year from the date of purchase. This warranty does not extend to subsequent purchasers, or purchases through a non-authorized dealer or auction site. Lance Larkin will not be held responsible for any amount of damage in excess of the retail purchase price of the BREW EXPRESS coffee system under any circumstances. Incidental and consequential damages are specifically excluded from coverage from this warranty.

The BREW EXPRESS coffee system is not intended for commercial food service use. This warranty does not apply to accessories or damage to unit from misuse or incorrect installation. It is further noted that using the brewer without a water filter or filtered water system (entire house filter) may void the warranty. This applies to areas where the water is not treated for sediment, high mineral content or hard-water characteristics.

RETURN/REPAIR POLICY: Any BREW EXPRESS unit found to be defective may be returned to Lance Larkin after proper authorization. Defective units returned to Lance Larkin within 1 year from the original date of purchase will be replaced or repaired. The repaired or replaced unit will then be warranted under the terms of the remainder of the warranty period. The customer is responsible for all shipping charges of returned units. During the warranty period Lance Larkin will be responsible for shipping charges back to the customer.

LIMITATIONS: This warranty does not cover accessories (brew baskets, carafes, etc) and defects resulting from normal everyday use, such as but not limited to chips, scratches, abrasions, and discoloration. Also, this warranty does not cover defects due to failure to follow installation or operation instructions, improper care, abuse, accidents, damage during shipping and unauthorized repair or alterations. All or any acts of nature or abnormal conditions causing malfunction or product failure are considered not to be the responsibility of Lance Larkin and this warranty. Any damage resulting from this condition will be sustained solely by purchaser.

STATE LAW RIGHTS: This warranty gives you specific legal rights. Some states do not allow limitations on how long an implied warranty lasts or the exclusions or limitations of incidental or consequential damages, so the inclusions or limitations stated herein may not apply. This warranty gives the purchaser specific rights; other rights which vary from state to state may also apply.

REQUEST FOR WARRANTY SERVICE: Contact Lance Larkin technical support by telephone, fax or mail. We suggest that you keep the original packaging in case it may be necessary to ship the unit. When returning the unit, include you name, address, phone number, dated sales receipt (or copy) with product serial number, problem description and repair/return authorization form.

WARRANTY ACTIVATION: Register warranty online at www.brewexpress.com/registration. Or register by mail, see information on following page.

WARRANTY

REGISTER FOR WARRANTY ONLINE AT [HTTP://WWW.LANCELARKIN.COM/WARRANTY](http://www.lancelarkin.com/warranty) OR FILL OUT THE FORM BELOW, CUT OUT AND SEND TO: LANCE LARKIN 2730 NW FRONT AVE PORTLAND, OREGON 97210 PLEASE REGISTER 30 DAYS AFTER PURCHASE. RETAIN RECEIPT FOR PROOF OF PURCHASE.

WARRANTY REGISTRATION CARD

NAME:

ADDRESS:

PHONE: EMAIL (OPTIONAL)

MODEL #: BE-104R BE-104C BE-110 BE-112 MBE-112

SERIAL #: PRODUCT #
SEE BACK OF UNIT OR BOX

DATE OF PURCHASE: PLACE OF PURCHASE:

APPLICATION: RESIDENTIAL RV OFFICE OTHER

INSTALLED BY: SELF CONTRACTOR PLUMBER ELECTRICIAN OTHER

ON A SCALE OF 1-5 SATISFACTION WITH PRODUCT: (1 DISSATISFIED - 5 VERY SATISFIED)

SUGGESTIONS:

WWW.BREWEXPRESS.COM

FOR CUSTOMER SERVICE OR TECHNICAL SERVICE PLEASE CALL (866)-268-5953

LANCE  LARKIN®

L I F E M A D E S I M P L E®